



EASY CANTILEVER GATE SPECIFICATION

Specifying cantilever sliding gates is made simple thanks to the unique Cantilever Gate service!

Visit www.cameuk.com/comunello and sign up for this online service which with a few details about your proposed project, will produce all of the required installation specifications & details.

Make sure you have the following details to hand:

- Gate weight
- Opening size
- Maximum overhang size
- Post type



You'll receive the following from us:

- Detailed Equipment List
- Equipment Price
- Foundation Specification
- Technical Documents

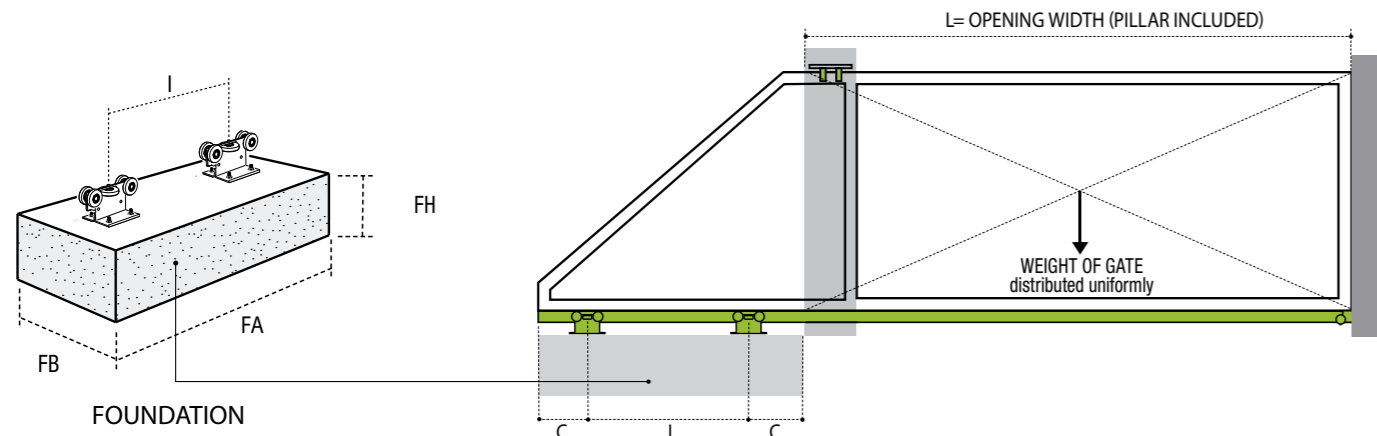

cameuk.com/comunello

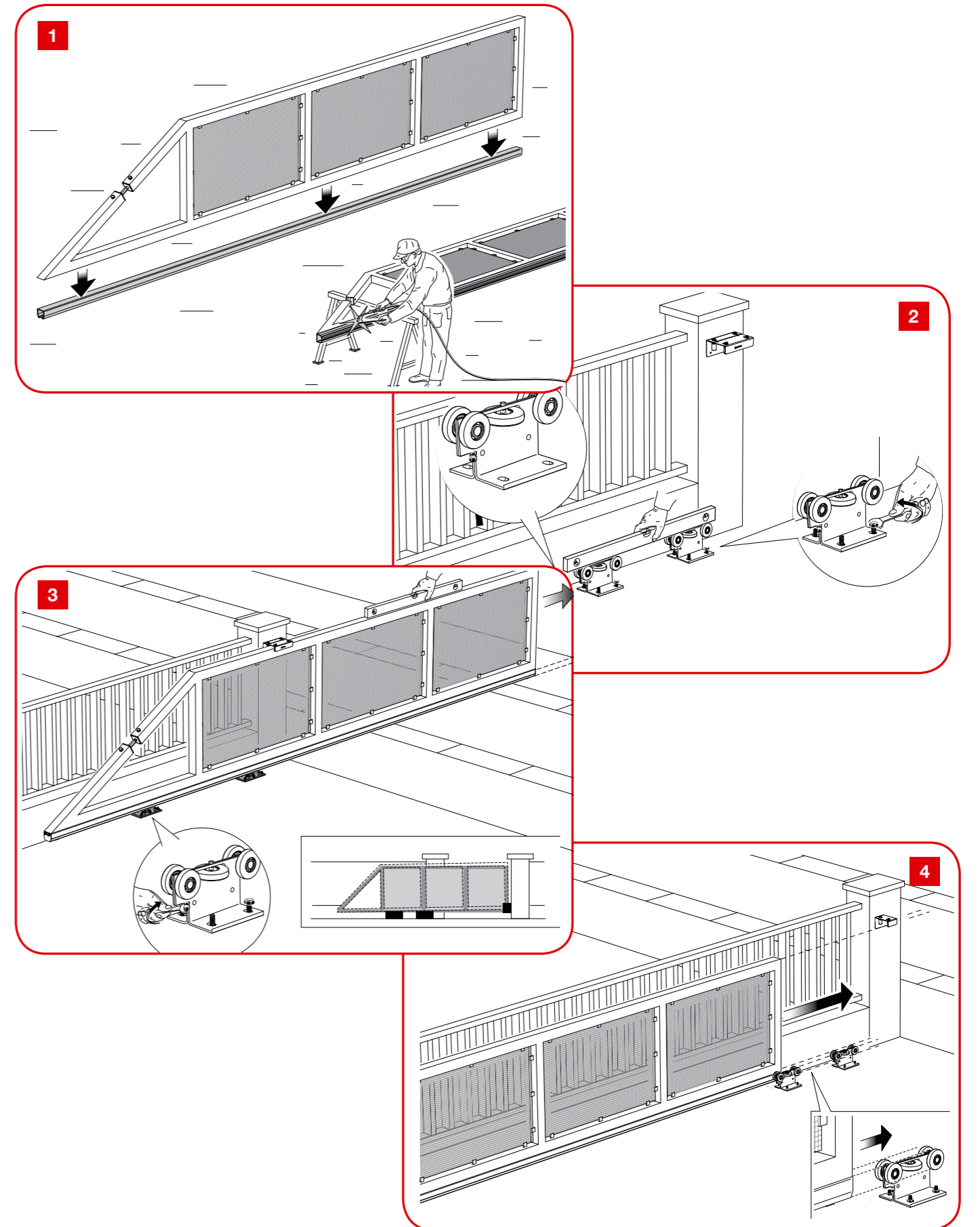

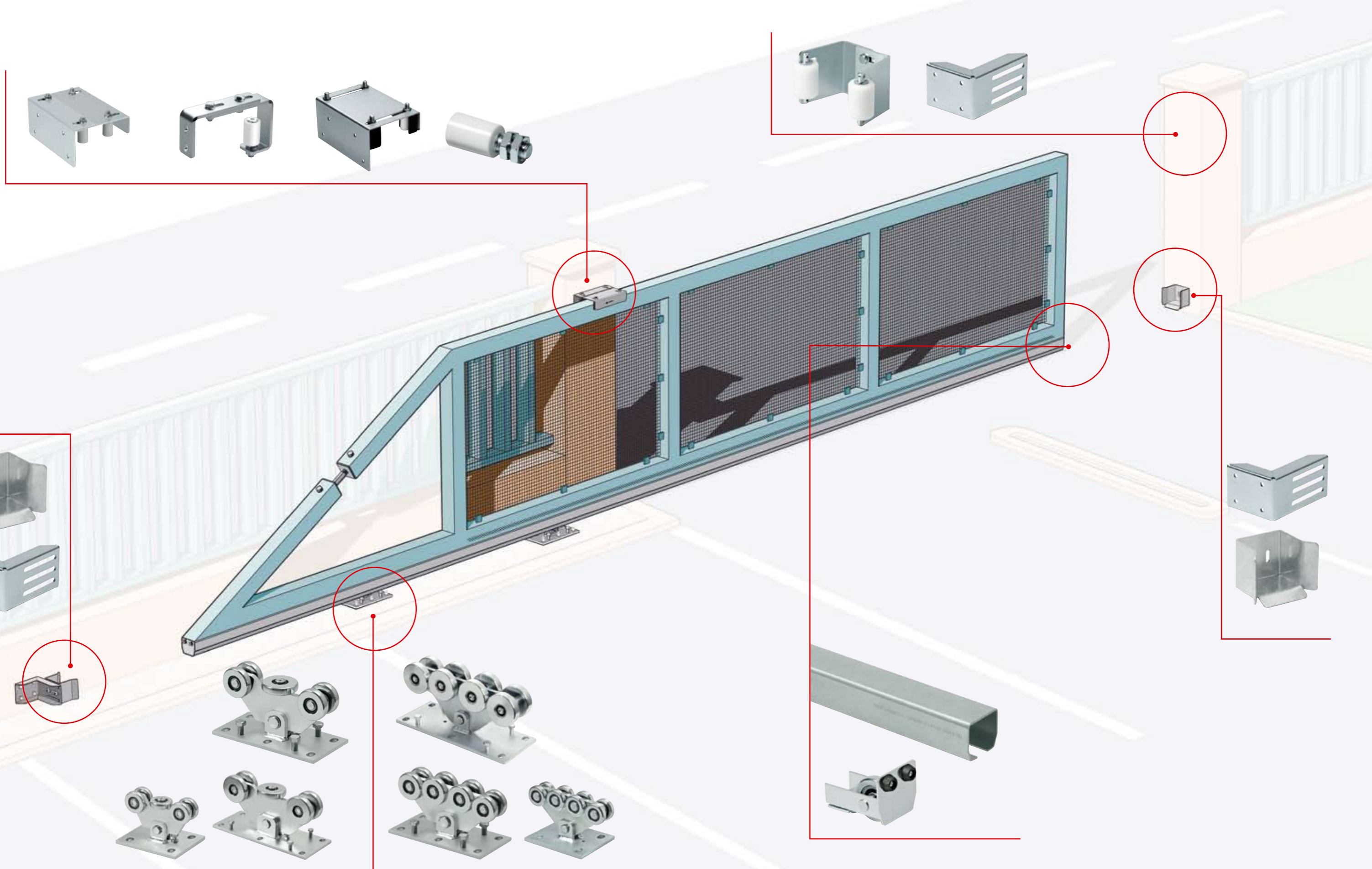

COMUNELLO CARRIAGES

Comunello

CGS150 Standard

STANDARD

The Comunello CGS150 range of cantilever carriages has been designed for lightweight cantilever gates in residential applications. Patented Comunello technology allows the CGS150 range to meet the requirements of the budget market without compromising on performance.

CGS250 Professional

PROFESSIONAL

Designed for large residential, multi-user and commercial cantilever gates, the CGS250 range meets the demands of the professional automated sliding gate installer. Capable of opening gates of up to 8m weighing 800kg

CGS350 Professional+Plus

PROFESSIONAL PLUS+

For exceedingly heavy or exceedingly large gates of up to 16m long. The CGS350 range is suitable for large commercial and industrial installations. Manufactured to the highest standards the CGS350 is more than capable of opening any gate under any circumstances.

Cantilever Range Application Guide

	CGS150	CGS250	CGS350
Residential	150.M 150.P	250.M	
Commercial	150.P	250.M 250.P	350.M
Industrial		250.G	350.P 250.G

CGS150 KITS

Comunello Professional Gate Hardware

IDEAL FOR



BX-243



150-300Kit

STANDARD

Cantilever gate kit for opening widths of up to 3m and gates weighing up to 300kg (including guide rail).

3m 300kg

	Qty		Qty
CGS-150.5M 5 Wheeled Carriage	2	230-30 Ø30 Guide Roller	4
CGS-347M Guide Wheel	1	CGS-245M -3m Galvanised Rail 3m	2
CGS-346M Meeting Plate	1		

IDEAL FOR



BX74 BX-P BX246



150-600Kit

STANDARD

Cantilever gate kit for opening widths of up to 6m and gates weighing up to 600kg (including guide rail).

6m 600kg

	Qty		Qty
CGS-150.5P 5 Wheeled Carriage	2	230-30 Ø30 Guide Roller	4
CGS-347P Guide Wheel	1	CGS-245P -3m Galvanised Rail 3m	3
CGS-346P Meeting Plate	1		

CGS150 EXAMPLES

KIT150-300k (3m opening)

Weight (KG)	Measurement (M)				
	I	C	FA	FB	FH
300	1.5	0.20	2.1	0.5	0.6
200	0.9	0.20	1.5	0.5	0.6
100	0.4	0.20	1.0	0.5	0.6

KIT150-600k (6m opening)

Weight (KG)	Measurement (M)				
	I	C	FA	FB	FH
600	3.7	0.30	4.6	0.5	0.6
500	2.7	0.30	3.4	0.5	0.6
400	2.0	0.30	2.6	0.5	0.6

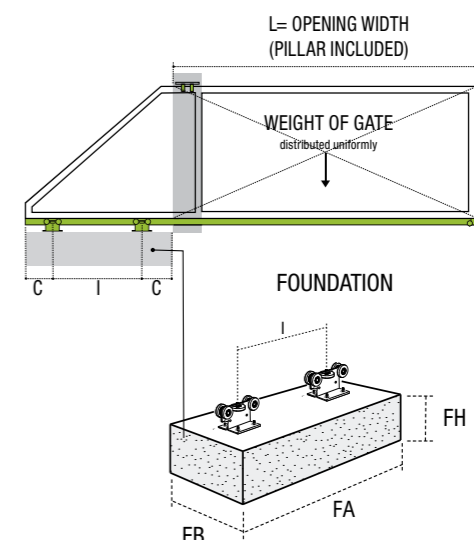

EASY SPECIFICATION!
Use our simple online specification tool at www.cameuk.com/comunello

- Detailed equipment list
- Equipment Price
- Foundation Specification
- Sliding Gate Specification

SEE PAGE 3 FOR FULL DETAILS

CGS250 KITS

IDEAL FOR



250-600Kit

Cantilever gate kit for opening widths of up to 7m and gates weighing up to 600kg (including guide rail).

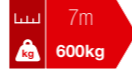

Component	Qty	Component	Qty
CGS-250.8P 8 Wheeled Carriage	2	230-30 Ø30 Guide Roller	4
CGS-347P Guide Wheel	1	CGS-245P-3M Galvanised Rail 3m	4
CGS-346P Meeting Plate	1		

IDEAL FOR



250-1200Kit

Cantilever gate kit for opening widths of up to 12m and gates weighing up to 1200kg (including guide rail).

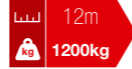

Component	Qty	Component	Qty
CGS-250.8G 8 Wheeled Carriage	2	230-30 Ø30 Guide Roller	4
CGS-347G Guide Wheel	1	CGS-245G-3M Galvanised Rail 3m	7
CGS-346G Meeting Plate	1		

CGS350 KITS

IDEAL FOR



350-800Kit

Cantilever gate kit for opening widths of up to 10m and gates weighing up to 800kg (including guide rail).



Component	Qty	Component	Qty
CGS-350.8P 8 Wheeled Carriage	2	230-30 Ø30 Guide Roller	4
CGS-347P Guide Wheel	1	CGS-345P-3M Galvanised Rail 3m	5
CGS-346P Meeting Plate	1		

IDEAL FOR



350-1800Kit

Cantilever gate kit for opening widths of up to 18m and gates weighing up to 1800kg (including guide rail).



Component	Qty	Component	Qty
CGS-350.8G 8 Wheeled Carriage	2	230-30 Ø30 Guide Roller	4
CGS-347G Guide Wheel	1	CGS-345G-3M Galvanised Rail 3m	10
CGS-346G Meeting Plate	1		

CGS250 EXAMPLES

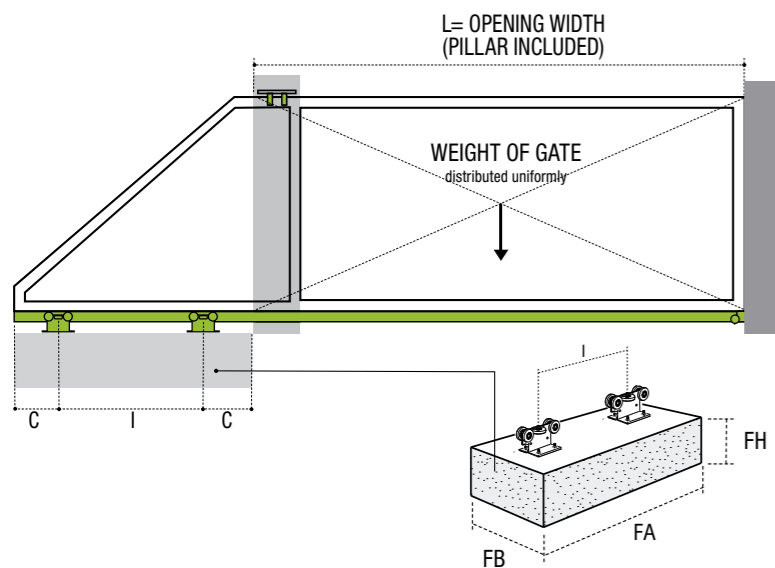

Weight (KG)	KIT250-600k (7m opening)				
	Measurement (M)				
	I	C	FA	FB	FH
400	1.77	0.33	2.47	0.7	1.09
500	2.36	0.33	3.06	0.7	0.6
600	3.11	0.33	3.81	0.7	0.6

Weight (KG)	KIT250-1200k (10m opening)				
	Measurement (M)				
	I	C	FA	FB	FH
800	3.91	0.46	4.81	0.9	0.6
1000	5.51	0.46	6.41	0.9	0.6
1200	7.89	0.46	8.79	0.9	0.6

CGS350 EXAMPLES

Weight (KG)	KIT350 - 800k (10m opening)				
	Measurement (M)				
	I	C	FA	FB	FH
600	3.06	0.33	3.76	0.7	0.6
700	3.79	0.33	4.49	0.7	0.6
800	4.86	0.33	5.38	0.7	0.6

Weight (KG)	KIT350 - 1800k (18m opening)				
	Measurement (M)				
	I	C	FA	FB	FH
1200	7.14	0.46	8.04	0.9	0.6
1400	8.97	0.46	9.87	0.9	0.6
1800	14.01	0.46	14.91	1.0	1.3

	TOTAL GATE LENGTH	
	8m Opening	16m Opening
250.8P	11.37m	-
350.8P	10.51m	-
250.8G	-	22.91m
350.8G	-	20.55m
% Saved	7.6%	10.3%

EASY SPECIFICATION!
Use our simple online specification tool at
www.cameuk.com/comunello
Detailed equipment list
Equipment Price
Foundation Specification
Sliding Gate Specification
SEE PAGE 3 FOR FULL DETAILS